Subject: To much polys?

Posted by [mrÄÅz](#) on Sun, 27 Jul 2008 18:03:27 GMT

[View Forum Message](#) <> [Reply to Message](#)

OK pretty much Polys, whats the standard Poly count of a normal renegade Weapon?

(WIP)

File Attachments

1) [MR_uzi.jpg](#), downloaded 475 times

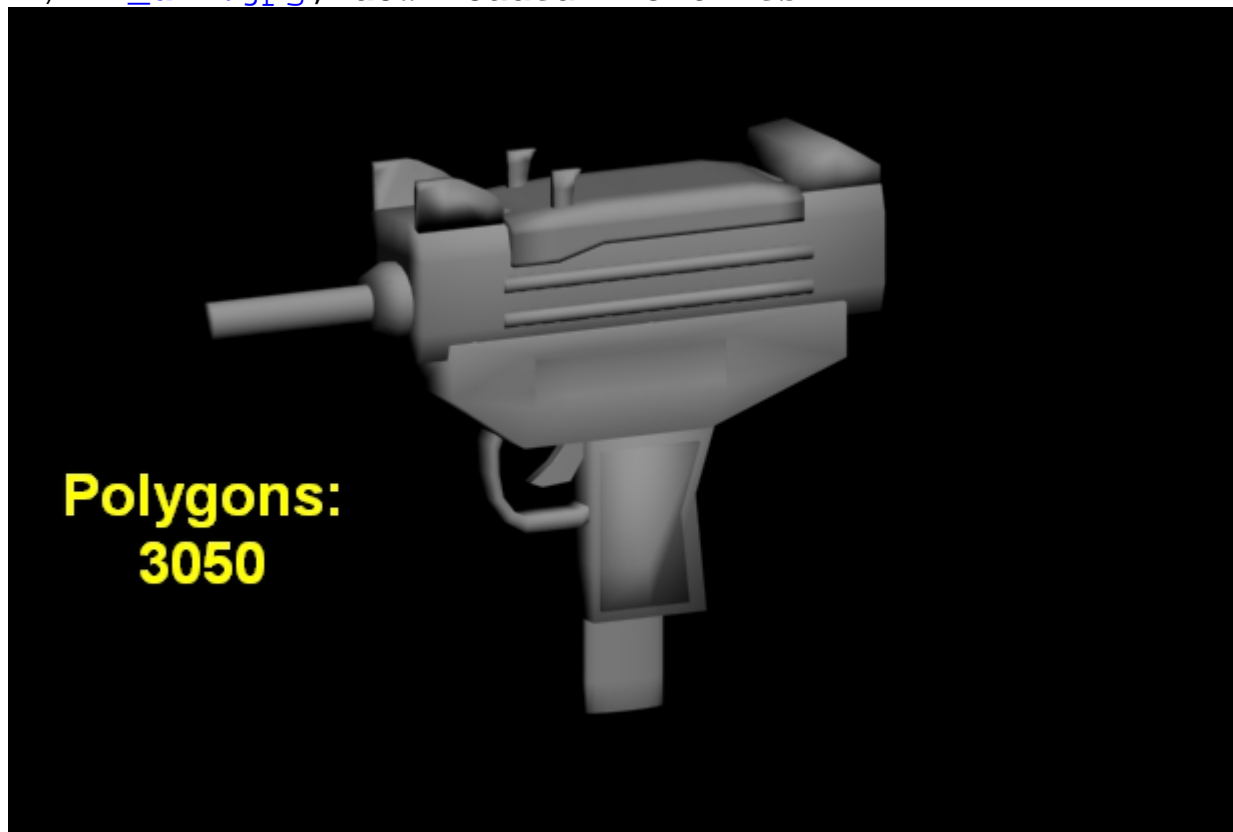

Subject: Re: To much polys?

Posted by [GEORGE ZIMMER](#) on Sun, 27 Jul 2008 18:07:16 GMT

[View Forum Message](#) <> [Reply to Message](#)

Regardless of what the standard polycount is for Renegade, that is WAAAAY too many for just that.

Also, are you referencing anything, or just making it out of nowhere?

Subject: Re: To much polys?

Posted by [mr£Ä\\$Ä-z](#) on Sun, 27 Jul 2008 18:26:05 GMT

[View Forum Message](#) <> [Reply to Message](#)

ehhh what? anyways its for a small own roleplay map im working on

check out this gun low polys still good?
(just test texture)

I want you guys to tell me what i do wrong and what i could do to make better models

File Attachments

1) [MR_Pistol.bmp](#), downloaded 371 times

Subject: Re: To much polys?

Posted by [cnc95fan](#) on Sun, 27 Jul 2008 18:27:11 GMT

[View Forum Message](#) <> [Reply to Message](#)

I woudn't put more then 500 polys into a weapon. Even that is pushing it.

Subject: Re: To much polys?

Posted by [mr£Ä\\$Ä-z](#) on Sun, 27 Jul 2008 18:41:15 GMT

[View Forum Message](#) <> [Reply to Message](#)

Do anyone know how much polys Reborn Weapons have?
Wouldnt 500 Polys look a bit empty ? And thanks for the info

Subject: Re: To much polys?

Posted by [GEORGE ZIMMER](#) on Sun, 27 Jul 2008 18:42:43 GMT

[View Forum Message](#) <> [Reply to Message](#)

Show some wireframe.

Subject: Re: To much polys?

Posted by [Canadacdn](#) on Sun, 27 Jul 2008 18:44:21 GMT

[View Forum Message](#) <> [Reply to Message](#)

Most weapons for first person can have around 2000 polygons with little change to your framerate. The third person model for your weapon should have less.

Subject: Re: To much polys?
Posted by [MGamer](#) on Sun, 27 Jul 2008 18:52:36 GMT
[View Forum Message](#) <> [Reply to Message](#)

o.o nice fat uzi lol

Subject: Re: To much polys?
Posted by [saberhawk](#) on Sun, 27 Jul 2008 18:54:57 GMT
[View Forum Message](#) <> [Reply to Message](#)

Canadacd wrote on Sun, 27 July 2008 13:44Most weapons for first person can have around 2000 polygons with little change to your framerate. The third person model for your weapon should have less.

Indeed. Renegade is CPU limited on most hardware so 3000 polys wouldn't cause any problems at all. Just make sure they are batched (aka 1 mesh, no per-vertex materials, etc) because the amount of draw calls do count.

Subject: Re: To much polys?
Posted by [mr£ÄŞÄ-z](#) on Sun, 27 Jul 2008 18:56:38 GMT
[View Forum Message](#) <> [Reply to Message](#)

Canadacd wrote on Sun, 27 July 2008 13:44Most weapons for first person can have around 2000 polygons with little change to your framerate. The third person model for your weapon should have less.
Nice to hear that

Quote:Cabal8616
Show some wireframe.

File Attachments

1) [Wireframe.bmp](#), downloaded 346 times

Subject: Re: To much polys?
Posted by [HeavyX101- Left](#) on Sun, 27 Jul 2008 18:59:18 GMT
[View Forum Message](#) <> [Reply to Message](#)

cnc95fan wrote on Sun, 27 July 2008 14:27I woudln't put more then 500 polys into a weapon. Even that is pushing it. That is why BfD is a fail.

Subject: Re: To much polys?
Posted by [GEORGE ZIMMER](#) on Sun, 27 Jul 2008 19:04:08 GMT
[View Forum Message](#) <> [Reply to Message](#)

HeavyX101 wrote on Sun, 27 July 2008 13:59cnc95fan wrote on Sun, 27 July 2008 14:27I woudln't put more then 500 polys into a weapon. Even that is pushing it. That is why BfD is a fail.
no u.

Also, most high poly weapons don't even use the poly's properly. The pistol seems somewhat alright, but holy shit, that uzi is TERRIBLE.

Subject: Re: To much polys?
Posted by [HeavyX101- Left](#) on Sun, 27 Jul 2008 19:26:21 GMT
[View Forum Message](#) <> [Reply to Message](#)

Cabal8616 wrote on Sun, 27 July 2008 15:04HeavyX101 wrote on Sun, 27 July 2008 13:59cnc95fan wrote on Sun, 27 July 2008 14:27I woudln't put more then 500 polys into a weapon. Even that is pushing it. That is why BfD is a fail.
no u.

Also, most high poly weapons don't even use the poly's properly. The pistol seems somewhat alright, but holy shit, that uzi is TERRIBLE.
Nice to meet you.

Subject: Re: To much polys?
Posted by [mrÃ£Ã§Ã-z](#) on Sun, 27 Jul 2008 19:32:15 GMT
[View Forum Message](#) <> [Reply to Message](#)

Cabal8616 wrote on Sun, 27 July 2008 14:04HeavyX101 wrote on Sun, 27 July 2008 13:59cnc95fan wrote on Sun, 27 July 2008 14:27I woudln't put more then 500 polys into a weapon. Even that is pushing it. That is why BfD is a fail.
no u.

Also, most high poly weapons don't even use the poly's properly. The pistol seems somewhat alright, but holy shit, that uzi is TERRIBLE.
Do it better, like i said im modeling just for like 10 days now

Subject: Re: To much polys?
Posted by [MGamer](#) on Sun, 27 Jul 2008 20:14:32 GMT
[View Forum Message](#) <> [Reply to Message](#)

after reading this i got bored and i modeled my first pistol lol
i stoped at 1030 polys

PS: it sucks

File Attachments

1) [test.bmp](#), downloaded 277 times

Subject: Re: To much polys?
Posted by [_SSnipe_](#) on Sun, 27 Jul 2008 20:22:41 GMT
[View Forum Message](#) <> [Reply to Message](#)

Saberhawk wrote on Sun, 27 July 2008 11:54Canadacdn wrote on Sun, 27 July 2008 13:44Most weapons for first person can have around 2000 polygons with little change to your framerate. The third person model for your weapon should have less.

Indeed. Renegade is CPU limited on most hardware so 3000 polys wouldn't cause any problems at all. Just make sure they are batched (aka 1 mesh, no per-vertex materials, etc) because the amount of draw calls do count.
id listen to saber

Subject: Re: To much polys?
Posted by [Canadacdn](#) on Sun, 27 Jul 2008 20:52:43 GMT
[View Forum Message](#) <> [Reply to Message](#)

MGamer wrote on Sun, 27 July 2008 16:14after reading this i got bored and i modeled my first pistol lol
i stoped at 1030 polys

PS: it sucks

That's actually not too bad. Just get a better texture for the sides and top and it would look good.

Subject: Re: To much polys?
Posted by [mr£Ä\\$Ä-z](#) on Sun, 27 Jul 2008 20:53:29 GMT
[View Forum Message](#) <> [Reply to Message](#)

wich tutorial did you use?

Subject: Re: To much polys?

Posted by [cnc95fan](#) on Sun, 27 Jul 2008 21:35:24 GMT

[View Forum Message](#) <> [Reply to Message](#)

HeavyX101 wrote on Sun, 27 July 2008 13:59cnc95fan wrote on Sun, 27 July 2008 14:27I woudln't put more then 500 polys into a weapon. Even that is pushing it.

That is why BfD is a fail.

Jesus christ you are such a fag. Your shitty cnc3 mod won't get anywhere with a fag leader like you. you would probably cheat in it if it got anywhere anyway, it won't go beyond the stage of texturing because you havn't a fucking clue how to do anything.

Subject: Re: To much polys?

Posted by [MGamer](#) on Sun, 27 Jul 2008 21:40:43 GMT

[View Forum Message](#) <> [Reply to Message](#)

madrackz wrote on Sun, 27 July 2008 15:53wich tutorial did you use?

o.o there is a tutorial for weapons? i just placed a pic of the Barrett M9 at the front viewport and i started to model

Subject: Re: To much polys?

Posted by [HeavyX101- Left](#) on Sun, 27 Jul 2008 22:47:23 GMT

[View Forum Message](#) <> [Reply to Message](#)

cnc95fan wrote on Sun, 27 July 2008 17:35HeavyX101 wrote on Sun, 27 July 2008 13:59cnc95fan wrote on Sun, 27 July 2008 14:27I woudln't put more then 500 polys into a weapon. Even that is pushing it.

That is why BfD is a fail.

Jesus christ you are such a fag. Your shitty cnc3 mod won't get anywhere with a fag leader like you. you would probably cheat in it if it got anywhere anyway, it won't go beyond the stage of texturing because you havn't a fucking clue how to do anything.

You say that because ur jealous that Tiberian Wrath is better than BfDuuh. BfD fails. I'm really sad that that idea got taked by a n00b like cnc95fan

Now shut up. Your a fag. I dont want to ruin my friends topic. Come to america and say the thing you want to say IN MY FACE!

Subject: Re: To much polys?

Posted by [cnc95fan](#) on Sun, 27 Jul 2008 22:54:59 GMT

[View Forum Message](#) <> [Reply to Message](#)

Why, can you not afford to fly over here? Surley you can sell some of those 3d models you made with your "epic skillz"

Subject: Re: To much polys?
Posted by [u6795](#) on Sun, 27 Jul 2008 23:06:52 GMT
[View Forum Message](#) <> [Reply to Message](#)

Will you two faggots just shut the fuck up?

Cncfan, you made the mistake. You gave in to his constant trolling, and this is your fault. I hope you're having fun.

This is fucking pathetic, beyond belief- MY MOD IS BETTER THAN YOURS, LOL. You know what? If you truly can play into that strategy then you're a massive douchebag.

Subject: Re: To much polys?
Posted by [HeavyX101- Left](#) on Sun, 27 Jul 2008 23:14:00 GMT
[View Forum Message](#) <> [Reply to Message](#)

u6795 wrote on Sun, 27 July 2008 19:06Will you two faggots just shut the fuck up?

Cncfan, you made the mistake. You gave in to his constant trolling, and this is your fault. I hope you're having fun.

This is fucking pathetic, beyond belief- MY MOD IS BETTER THAN YOURS, LOL. You know what? If you truly can play into that strategy then you're a massive douchebag.
He started first. He said that Tiberian Wrath is a failmod. I agree with him because it is not done yet.
And i have some other mods that i'm working on and i dont have lots of time working on mine.

Subject: Re: To much polys?
Posted by [u6795](#) on Sun, 27 Jul 2008 23:16:47 GMT
[View Forum Message](#) <> [Reply to Message](#)

HeavyX101 wrote on Sun, 27 July 2008 19:14u6795 wrote on Sun, 27 July 2008 19:06Will you two faggots just shut the fuck up?

Cncfan, you made the mistake. You gave in to his constant trolling, and this is your fault. I hope you're having fun.

This is fucking pathetic, beyond belief- MY MOD IS BETTER THAN YOURS, LOL. You know what? If you truly can play into that strategy then you're a massive douchebag.
He started first. He said that Tiberian Wrath is a failmod. I agree with him because it is not done yet.
And i have some other mods that i'm working on and i dont have lots of time working on mine.
I don't give a shit who started it- you're both acting like immature little children trying to swing their dicks around and look cooler.

Fuck, I feel like a kindergarten teacher. Sometimes I think that's what these forums are, a big

kindergarten playground. Judging by the retarded bullshit that gets said around here I guess it wouldn't be too far off.

Subject: Re: To much polys?

Posted by [HeavyX101- Left](#) on Sun, 27 Jul 2008 23:18:57 GMT

[View Forum Message](#) <> [Reply to Message](#)

u6795 wrote on Sun, 27 July 2008 19:16HeavyX101 wrote on Sun, 27 July 2008 19:14u6795 wrote on Sun, 27 July 2008 19:06Will you two faggots just shut the fuck up?

Cncfan, you made the mistake. You gave in to his constant trolling, and this is your fault. I hope you're having fun.

This is fucking pathetic, beyond belief- MY MOD IS BETTER THAN YOURS, LOL. You know what? If you truly can play into that strategy then you're a massive douchebag. He started first. He said that Tiberian Wrath is a failmod. I agree with him because it is not done yet.

And i have some other mods that i'm working on and i dont have lots of time working on mine. I don't give a shit who started it- you're both acting like immature little children trying to swing their dicks around and look cooler.

Fuck, I feel like a kindergarten teacher. Sometimes I think that's what these forums are, a big kindergarten playground. Judging by the retarded bullshit that gets said around here I guess it wouldn't be too far off.

That would be cool. A kindergarten teacher playing renegade and saying bad words.

Subject: Re: To much polys?

Posted by [MGamer](#) on Mon, 28 Jul 2008 01:03:50 GMT

[View Forum Message](#) <> [Reply to Message](#)

HeavyX101 wrote on Sun, 27 July 2008 18:18u6795 wrote on Sun, 27 July 2008 19:16HeavyX101 wrote on Sun, 27 July 2008 19:14u6795 wrote on Sun, 27 July 2008 19:06Will you two faggots just shut the fuck up?

Cncfan, you made the mistake. You gave in to his constant trolling, and this is your fault. I hope you're having fun.

This is fucking pathetic, beyond belief- MY MOD IS BETTER THAN YOURS, LOL. You know what? If you truly can play into that strategy then you're a massive douchebag. He started first. He said that Tiberian Wrath is a failmod. I agree with him because it is not done yet.

And i have some other mods that i'm working on and i dont have lots of time working on mine. I don't give a shit who started it- you're both acting like immature little children trying to swing their dicks around and look cooler.

Fuck, I feel like a kindergarten teacher. Sometimes I think that's what these forums are, a big kindergarten playground. Judging by the retarded bullshit that gets said around here I guess it wouldn't be too far off.

That would be cool. A kindergarten teacher playing renegade and saying bad words.

LOL

Subject: Re: To much polys?

Posted by [Dreganius](#) on Mon, 28 Jul 2008 05:19:33 GMT

[View Forum Message](#) <> [Reply to Message](#)

MGamer wrote on Mon, 28 July 2008 11:03HeavyX101 wrote on Sun, 27 July 2008 18:18u6795 wrote on Sun, 27 July 2008 19:16HeavyX101 wrote on Sun, 27 July 2008 19:14u6795 wrote on Sun, 27 July 2008 19:06Will you two faggots just shut the fuck up?

Cncfan, you made the mistake. You gave in to his constant trolling, and this is your fault. I hope you're having fun.

This is fucking pathetic, beyond belief- MY MOD IS BETTER THAN YOURS, LOL. You know what? If you truly can play into that strategy then you're a massive douchebag.

He started first. He said that Tiberian Wrath is a failmod. I agree with him because it is not done yet.

And i have some other mods that i'm working on and i dont have lots of time working on mine.

I don't give a shit who started it- you're both acting like immature little children trying to swing their dicks around and look cooler.

Fuck, I feel like a kindergarten teacher. Sometimes I think that's what these forums are, a big kindergarten playground. Judging by the retarded bullshit that gets said around here I guess it wouldn't be too far off.

That would be cool. A kindergarten teacher playing renegade and saying bad words.

LOL

Subject: Re: To much polys?

Posted by [mr£ÄŞÄ-z](#) on Mon, 28 Jul 2008 16:28:51 GMT

[View Forum Message](#) <> [Reply to Message](#)

XD nice chair

Subject: Re: To much polys?

Posted by [LR01](#) on Fri, 01 Aug 2008 18:36:41 GMT

[View Forum Message](#) <> [Reply to Message](#)

madrackz wrote on Sun, 27 July 2008 20:56Canadacd wrote on Sun, 27 July 2008 13:44Most weapons for first person can have around 2000 polygons with little change to your framerate. The

third person model for your weapon should have less.
Nice to hear that

Quote:Cabal8616
Show some wireframe.

care for a little tip?
I think I see some poly's that can't be seen, try to get rid of them, that would take the poly count down
