Subject: Another WIP Map

Posted by [JeepRubi](#) on Mon, 16 Jan 2006 21:02:50 GMT

[View Forum Message](#) <> [Reply to Message](#)

Ive been working on this map for a couple of days and thought it would be neat to show you an update evry once in a while. This way i can get suggestions on the terrain before i put it into level edit. So far it has no texture and all i have is the terrain for the Nod and GDI bases.

Its gunna take awhile because of the way im modeling the terrain but the end result will be awesome.

File Attachments

1) [GDIBase 1.jpg](#), downloaded 755 times

Perspective

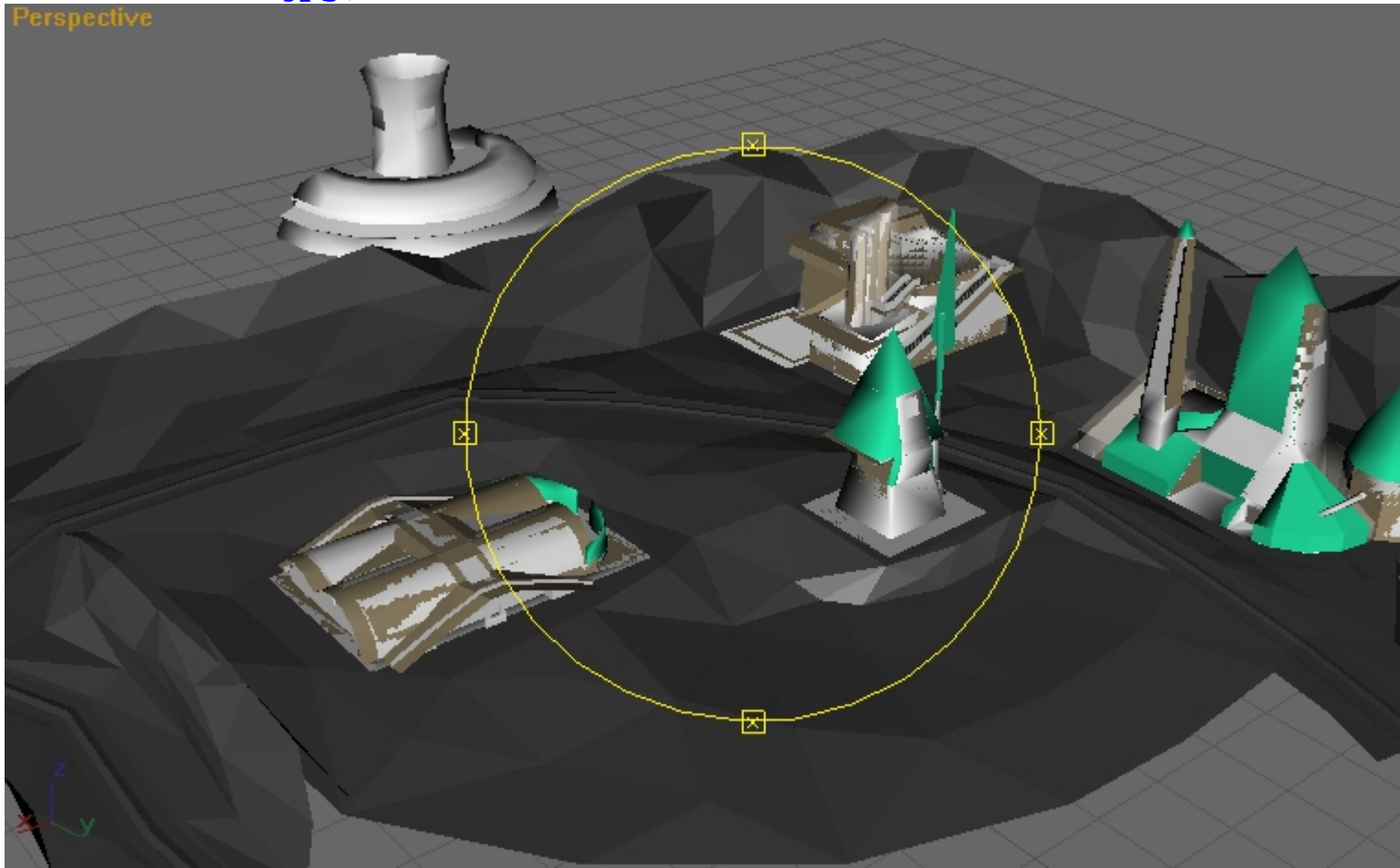

2) [GDIBase 2.jpg](#), downloaded 211 times

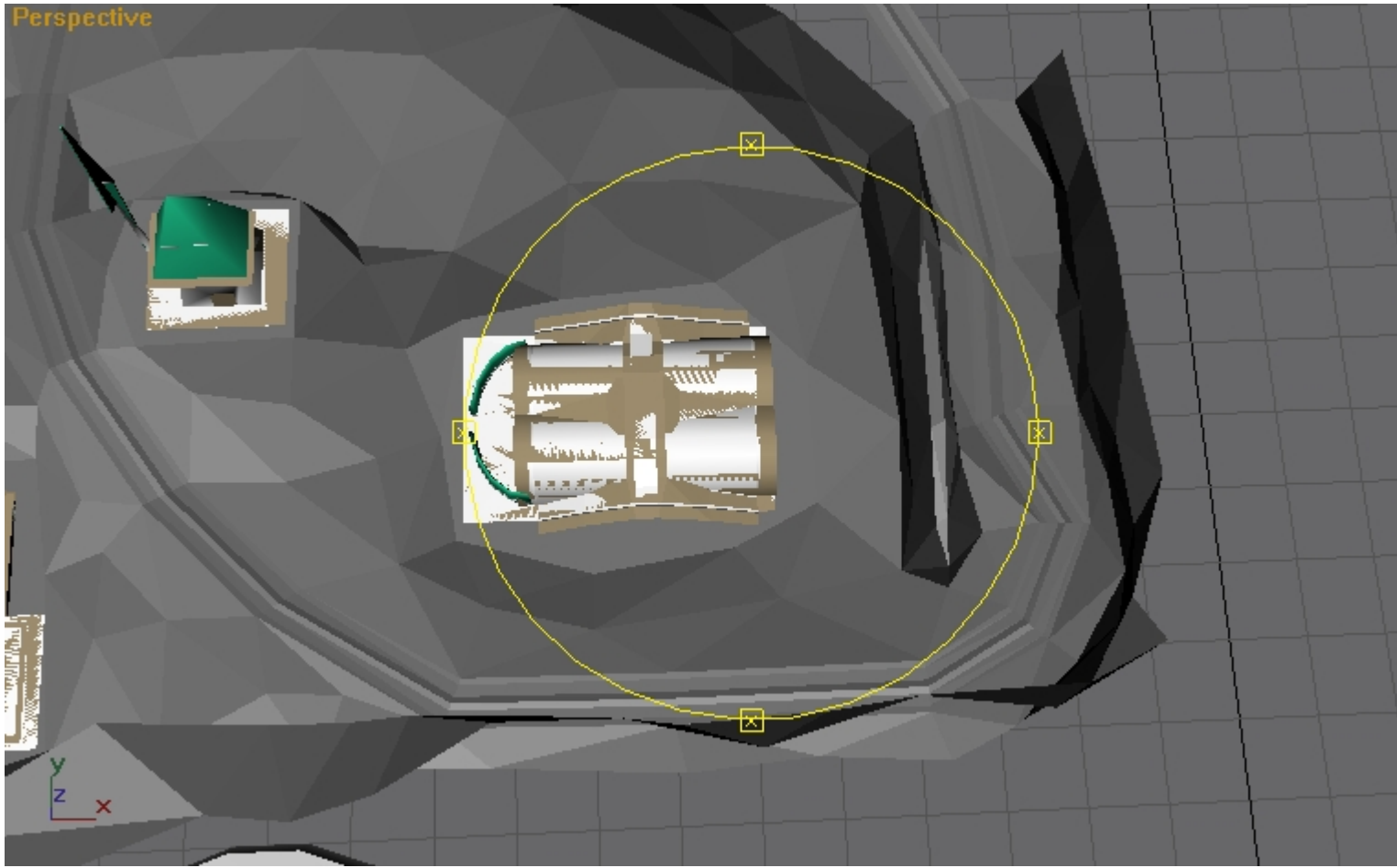

3) [Nodbase 1.jpg](#), downloaded 746 times

Perspective

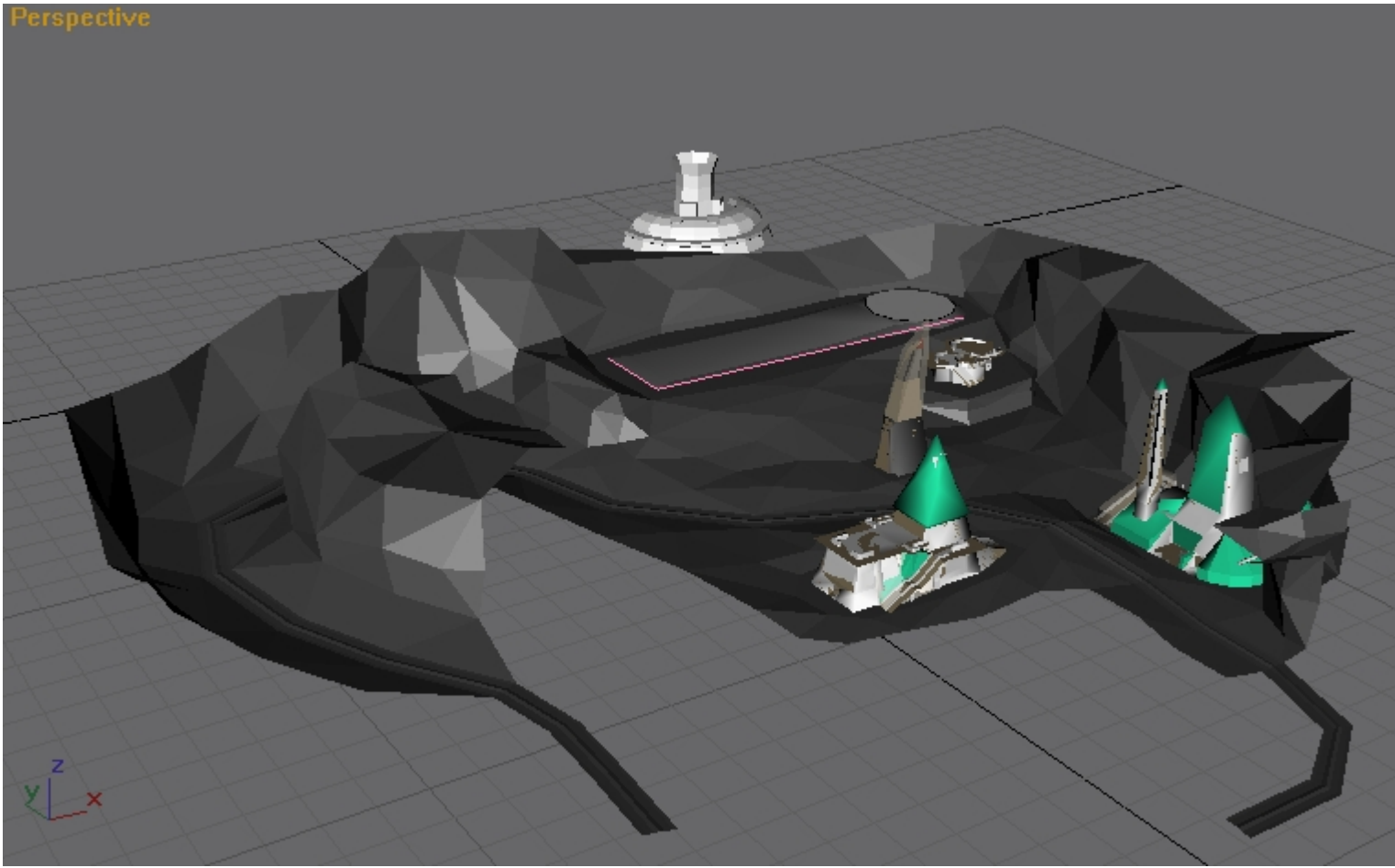

4) [Nodbase 2.jpg](#), downloaded 741 times

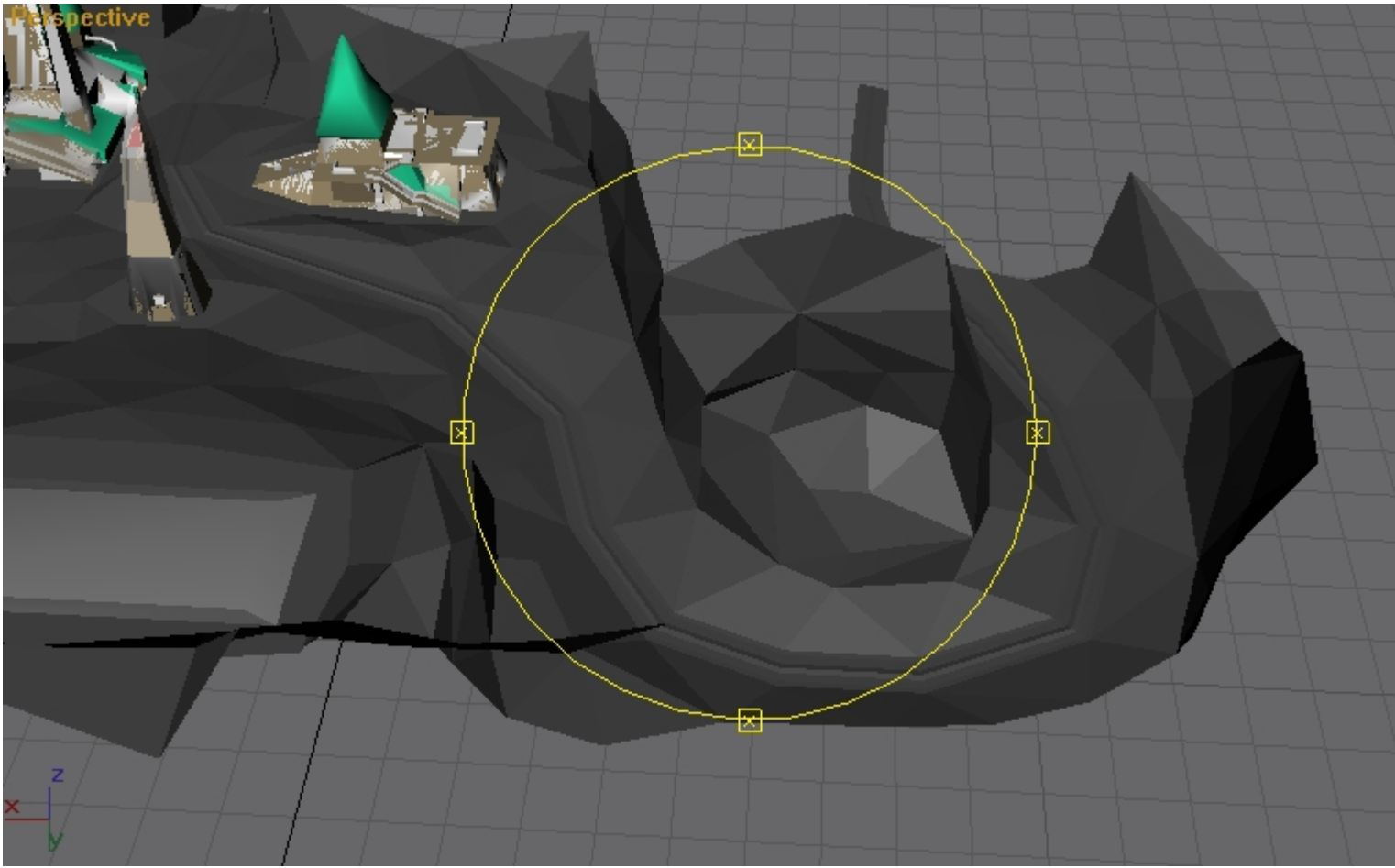

Subject: Re: Another WIP Map
Posted by [bisen11](#) on Mon, 16 Jan 2006 21:12:33 GMT
[View Forum Message](#) <> [Reply to Message](#)

Is the PP gonna be added in or what?

Subject: Re: Another WIP Map
Posted by [JeepRubi](#) on Mon, 16 Jan 2006 21:33:06 GMT
[View Forum Message](#) <> [Reply to Message](#)

No, the Power Plant is going to be in the background. It will be invincible, untargetable and will have no effect on gameplay whatsoever. All it is, is part of the scenery.

Subject: Re: Another WIP Map
Posted by [Spice](#) on Mon, 16 Jan 2006 21:40:02 GMT
[View Forum Message](#) <> [Reply to Message](#)

That's a neat idea. I like it. The map kind of looks like the tutorial map in renegade, better know as C&C_Land.

Try apply smoohting groups to your terrain, It will look a lot better.

Subject: Re: Another WIP Map
Posted by [JeepRubi](#) on Mon, 16 Jan 2006 22:10:11 GMT
[View Forum Message](#) <> [Reply to Message](#)

Couple things, im not going to smooth the terrain until im done. The reason it is not smoothed already is that the way i model is holding shift to create a poly then creat the face in between. I find this takes longer but you can get EXactly the thing you want.

And i am basing the nod base layout on C&C Land but on more of a hill. The texture set will be nearly the same.

Subject: Re: Another WIP Map
Posted by [JeepRubi](#) on Fri, 20 Jan 2006 01:29:06 GMT
[View Forum Message](#) <> [Reply to Message](#)

Got another update, ive been doing other things lately but i did a bit in the middle. I also textures quickly, they are only temorary.

File Attachments

1) [W3dview 2005-12-19 20-21-13-09.jpg](#), downloaded 650 times

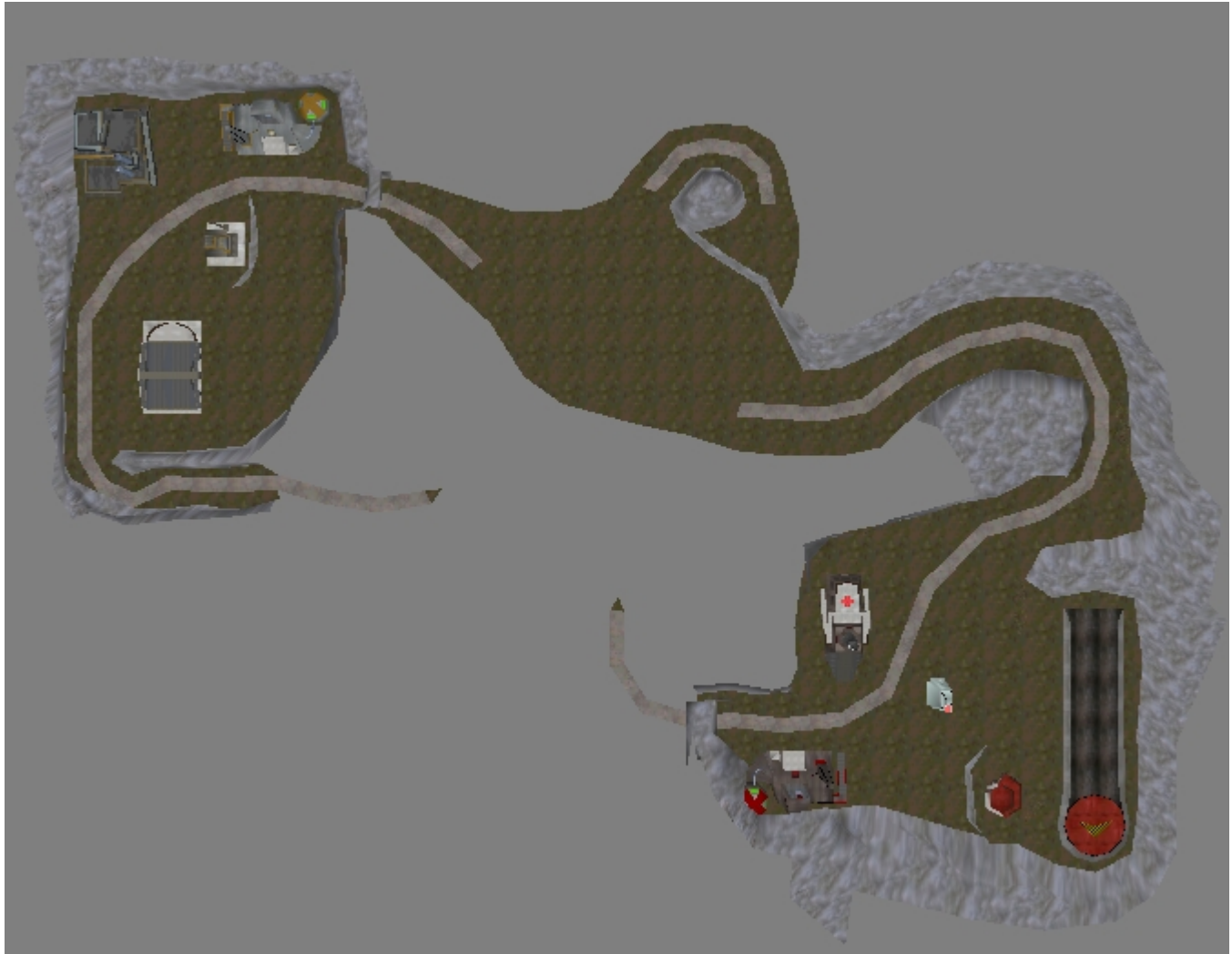

Subject: Re: Another WIP Map

Posted by [YSLMuffins](#) on Fri, 20 Jan 2006 02:09:03 GMT

[View Forum Message](#) <> [Reply to Message](#)

What's going to happen in the middle? Is it going to be like Field?

And it seems like the obelisk has a straight LOS onto most of the entrance to the Nod base; as in tanks will get zapped before getting to that corner closest to the airstrip out of sight of the obelisk.

Subject: Re: Another WIP Map

Posted by [=HT=T-Bird](#) on Fri, 20 Jan 2006 02:30:44 GMT

[View Forum Message](#) <> [Reply to Message](#)

EXdeath7 wrote on Mon, 16 January 2006 15:40 That's a neat idea. I like it. The map kind of looks like the tutorial map in renegade, better know as C&C_Land.

Try apply smoohting groups to your terrain, It will look a lot better.
Isn't the skirmish map in Ren actually a slightly modified version of C&C_Under?

Subject: Re: Another WIP Map
Posted by [Napalmic](#) on Fri, 20 Jan 2006 03:16:25 GMT
[View Forum Message](#) <> [Reply to Message](#)

=HT=T-Bird wrote on Thu, 19 January 2006 18:30EXdeath7 wrote on Mon, 16 January 2006 15:40That's a neat idea. I like it. The map kind of looks like the tutorial map in renegade, better know as C&C_Land.

Try apply smoohting groups to your terrain, It will look a lot better.
Isn't the skirmish map in Ren actually a slightly modified version of C&C_Under?

No he was talking about the solo player tutorial map which is C&C_Land, not the multiplayer practice one that you are correct, is C&C Under with a few changes.

Subject: Re: Another WIP Map
Posted by [Spice](#) on Fri, 20 Jan 2006 04:21:16 GMT
[View Forum Message](#) <> [Reply to Message](#)

From what I understand, C&C Land was the first renegade multiplayer map, which was modified for that tutorial map.

Subject: Re: Another WIP Map
Posted by [JeepRubi](#) on Mon, 23 Jan 2006 21:06:30 GMT
[View Forum Message](#) <> [Reply to Message](#)

Ok, another update. Im done most of the terrain exept some just outside the gdi base which i will probably get finished tonight. All i have for now are some plans for the tunnels. If anyone wants to comment on the way they will be set up i am open to opinions. If you look near the center were there is an infantry only area to cross from one feild to the next, you will notice two platforms. They are up in the rock face, i plan to add a small, very small rope bridge so you will be able to cross over and reach the other set of tunnels.

I am planning to make the map with the same texture set as C&C_Land. If people like the layout of the map ill do like C&C_Seside_Sunset and C&C_Seaside_Canyon and make two versions. This time it will be at night, the texture set will be more of a snowy cold and i might enable flying units.

I am still in need of a name so please post your ideas.

File Attachments

1) [map, map.jpg](#), downloaded 587 times

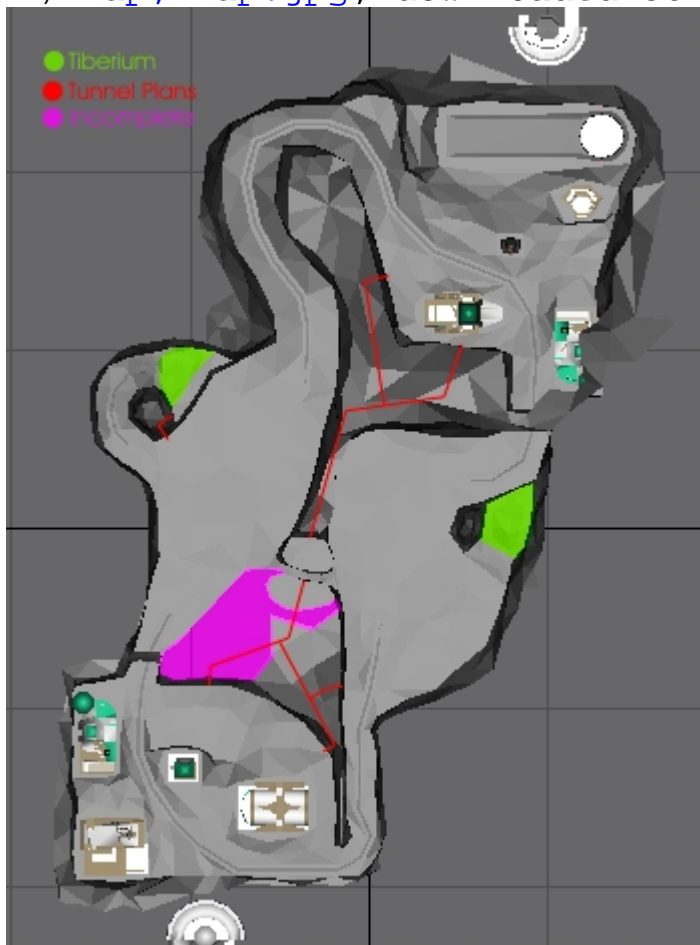

Subject: Re: Another WIP Map

Posted by [icedog90](#) on Tue, 24 Jan 2006 20:27:16 GMT

[View Forum Message](#) <> [Reply to Message](#)

Nod seems to have a slight advantage in the map.

Subject: Re: Another WIP Map

Posted by [JeepRubi](#) on Tue, 24 Jan 2006 21:51:56 GMT

[View Forum Message](#) <> [Reply to Message](#)

How could i fix this imbalance? Please post your ideas.

Subject: Re: Another WIP Map

Posted by [Mad Ivan](#) on Tue, 24 Jan 2006 22:31:59 GMT

[View Forum Message](#) <> [Reply to Message](#)

icedog90 wrote on Tue, 24 January 2006 15:27Nod seems to have a slight advantage in the map. with that tunnel leading straight into the hon?

Subject: Re: Another WIP Map
Posted by [JeepRubi](#) on Tue, 24 Jan 2006 23:32:11 GMT
[View Forum Message](#) <> [Reply to Message](#)

I made the map so both teams are about even, its harder for gdi to use its armour because there is so much of an area before the obliisk but its hard for nod to use its stealth because its a tighter map and the tunnels are far away from most buildings.

Subject: Re: Another WIP Map
Posted by [Mad Ivan](#) on Wed, 25 Jan 2006 00:56:11 GMT
[View Forum Message](#) <> [Reply to Message](#)

I suggest you add some rocks, barbed wire/sandbags in the field for snipers.

Also, what will the player see from outside the map, besides the Powerplants?

Subject: Re: Another WIP Map
Posted by [icedog90](#) on Wed, 25 Jan 2006 01:18:34 GMT
[View Forum Message](#) <> [Reply to Message](#)

The main path that leads to Nod's base is much longer and wider than GDI's. It seems like Nod would have an advantage there.

Subject: Re: Another WIP Map
Posted by [JeepRubi](#) on Mon, 30 Jan 2006 02:01:44 GMT
[View Forum Message](#) <> [Reply to Message](#)

Ok i finished the tunnels and the terrain, i also broke it upfor texturing and maybe vis sectors if it needs it.

File Attachments

1) [Wip Map.jpg](#), downloaded 498 times

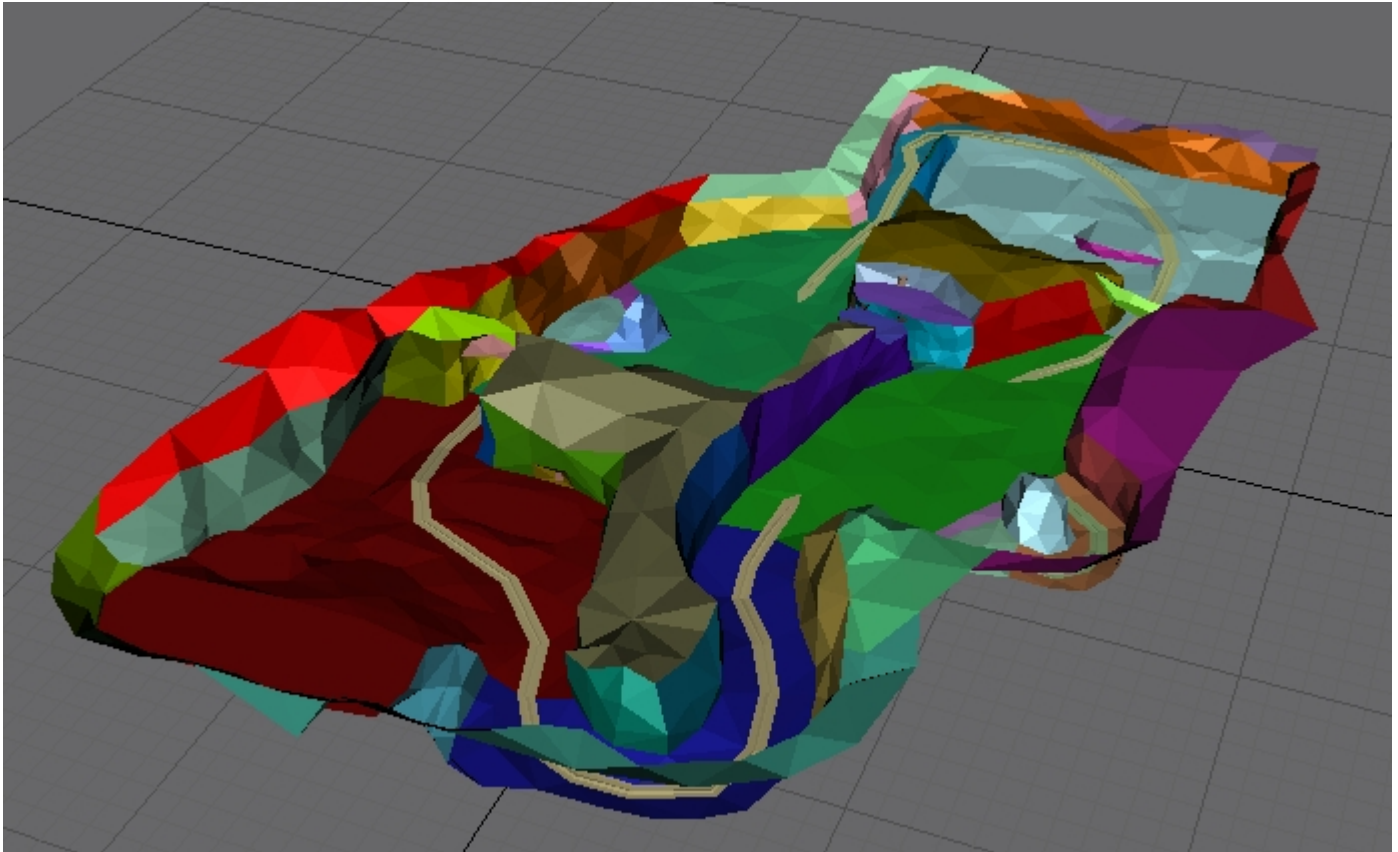

Subject: Re: Another WIP Map
Posted by [icedog90](#) on Mon, 30 Jan 2006 03:06:28 GMT
[View Forum Message](#) <> [Reply to Message](#)

Didn't take my advice...

Subject: Re: Another WIP Map
Posted by [Kamuix](#) on Mon, 30 Jan 2006 03:24:30 GMT
[View Forum Message](#) <> [Reply to Message](#)

Quote:I've been working on this map for a couple of days

Umm... Mines better.

Subject: Re: Another WIP Map
Posted by [JeepRubi](#) on Mon, 30 Jan 2006 13:08:06 GMT
[View Forum Message](#) <> [Reply to Message](#)

Somehow , i think mine will be better.

And icedog, sorry, i forgot about your idea ill try to make the nod path smaller.

Subject: Re: Another WIP Map

Posted by [JeepRubi](#) on Fri, 03 Feb 2006 00:53:24 GMT

[View Forum Message](#) <> [Reply to Message](#)

Ive been texturing and its looking awesome. One thing, I want to add a backdrop to it but I dont know what the texture is called. I looked through the always.dat and didnt see it (probably missed it). Anyone know the name of the one with the mounains like used on C&C_Land?

Subject: Re: Another WIP Map

Posted by [Spice](#) on Fri, 03 Feb 2006 04:42:46 GMT

[View Forum Message](#) <> [Reply to Message](#)

Since the GDI infantry can sneak in and desroy the hand of nod you should mak the GDI Barracks exposed to vehicle fire. Like so:

File Attachments

1) [test1.jpg](#), downloaded 557 times

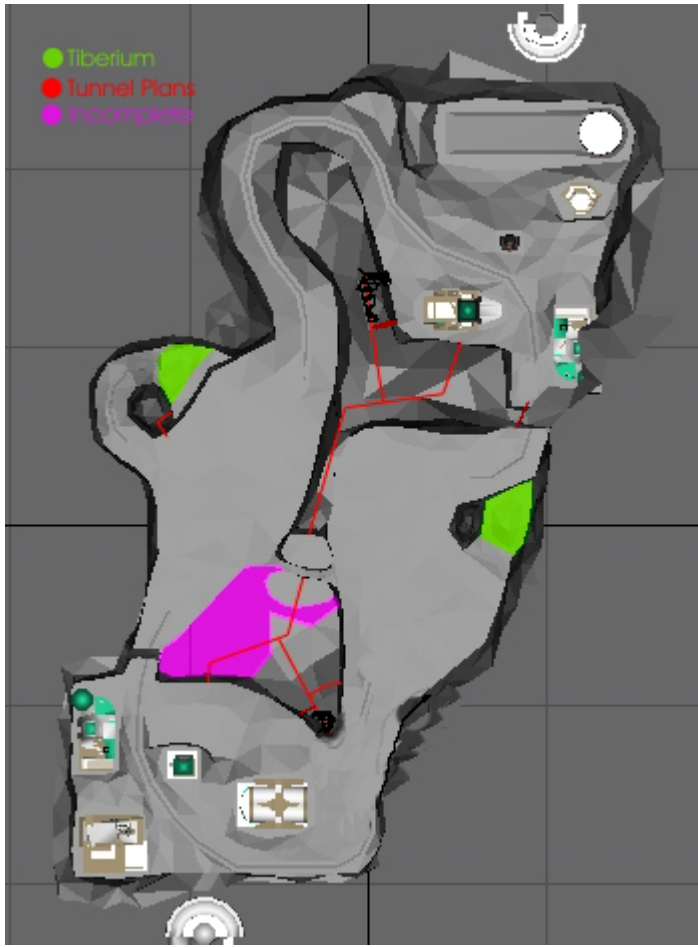

Subject: Re: Another WIP Map

Posted by [JeepRubi](#) on Fri, 03 Feb 2006 12:23:13 GMT

[View Forum Message](#) <> [Reply to Message](#)

If i did that it would not just make the barracks vanurable ut also every other building in the base.

I have some ideas to even it out that im currently working on.

Subject: Re: Another WIP Map

Posted by [PaRaDoX](#) on Fri, 03 Feb 2006 12:40:11 GMT

[View Forum Message](#) <> [Reply to Message](#)

i really like the way this is set up, exdeath7 is right though

Subject: Re: Another WIP Map

Posted by [Spice](#) on Sat, 04 Feb 2006 13:58:01 GMT

[View Forum Message](#) <> [Reply to Message](#)

The AGT would stop anything else besides artilleries, they might be able to hit the War factory aswell as the barracks.

GDI has infantry access to the hand of nod and ped, nod doesn't have access to anything. Not to mention GDI can point where their ref with anything. Nod can rush.. That's about it.

Subject: Re: Another WIP Map
Posted by [JeepRubi](#) on Sat, 04 Feb 2006 14:12:32 GMT
[View Forum Message](#) <> [Reply to Message](#)

The ped will be in the middle of the base on some.... thing i will make.

Subject: Re: Another WIP Map
Posted by [DreamWraith](#) on Sat, 04 Feb 2006 22:29:03 GMT
[View Forum Message](#) <> [Reply to Message](#)

I agree with exdeath about the balance.

I thought i would also note, since the PP is an external scenery item, you might want to delete the proxy for the internal mesh, as it wont be needed, if you haven't already done that. Would be a waste of poly's.

Also, as far as adding scenery, i would suggest just making some low polygon mountains in the background, and maybe adding some low poly tree models.

Subject: Re: Another WIP Map
Posted by [JeepRubi](#) on Sun, 05 Feb 2006 00:29:16 GMT
[View Forum Message](#) <> [Reply to Message](#)

for scenery im adding a backdrop if someone would tell me what the texture is called for the mountains.

Subject: Re: Another WIP Map
Posted by [DreamWraith](#) on Sun, 05 Feb 2006 01:28:13 GMT
[View Forum Message](#) <> [Reply to Message](#)

Jeep Rubi wrote on Sat, 04 February 2006 18:29 for scenery im adding a backdrop if someone would tell me what the texture is called for the mountains.

I don't know what it is. But I don't understand why you don't make it more realistic and just make some simple mountain meshes. Would take all of ten minutes, and you shouldn't need to use more than 200 polygons.

Subject: Re: Another WIP Map
Posted by [JeepRubi](#) on Mon, 13 Feb 2006 17:16:28 GMT
[View Forum Message](#) <> [Reply to Message](#)

EXdeath7 wrote on Thu, 02 February 2006 22:42 Since the GDI infantry can sneak in and desroy the hand of nod you should mak the GDI Barracks exposed to vehicle fire. Like so:

I took off the barrier half way instead of all the way. It acctually works better.

Subject: Re: Another WIP Map
Posted by [Titan1x77](#) on Mon, 13 Feb 2006 18:43:39 GMT
[View Forum Message](#) <> [Reply to Message](#)

DreamWraith wrote on Sat, 04 February 2006 17:29 I agree with exdeath about the balance.

I thought i would also note, since the PP is an external scenery item, you might want to delete the proxy for the internal mesh, as it wont be needed, if you haven't already done that. Would be a waste of poly's.

Also, as far as adding scenery, i would suggest just making some low polygon mountains in the background, and maybe adding some low poly tree models.

good advice....just make sure you keep the door proxys or place some doors that dont open on the external mesh of the PP's.

Maps looking good...keep it up

Subject: Re: Another WIP Map
Posted by [JeepRubi](#) on Mon, 13 Feb 2006 20:51:11 GMT
[View Forum Message](#) <> [Reply to Message](#)

For the backdrop, ill make some low poly mountains but id still like a 2d backdrop to end it.

Someone tell me what the texture is called for the mountain backdrop please! I dont want to go

through the always.dat for an hour.

Subject: Re: Another WIP Map

Posted by [DreamWraith](#) on Mon, 13 Feb 2006 21:23:22 GMT

[View Forum Message](#) <> [Reply to Message](#)

im not sure. if you know what level you've seen it in, that would be a good start to finding out.

Subject: Re: Another WIP Map

Posted by [JeepRubi](#) on Mon, 13 Feb 2006 21:31:41 GMT

[View Forum Message](#) <> [Reply to Message](#)

Either M02 or C&C_Feild

Subject: Re: Another WIP Map

Posted by [JeepRubi](#) on Tue, 14 Feb 2006 13:44:19 GMT

[View Forum Message](#) <> [Reply to Message](#)

And yet another update. (only pictures this time)

File Attachments

1) [W3dview 2006-02-14 08-40-53-00.jpg](#), downloaded 309 times



2) [W3dview 2006-02-14 08-40-45-39.jpg](#), downloaded 312 times

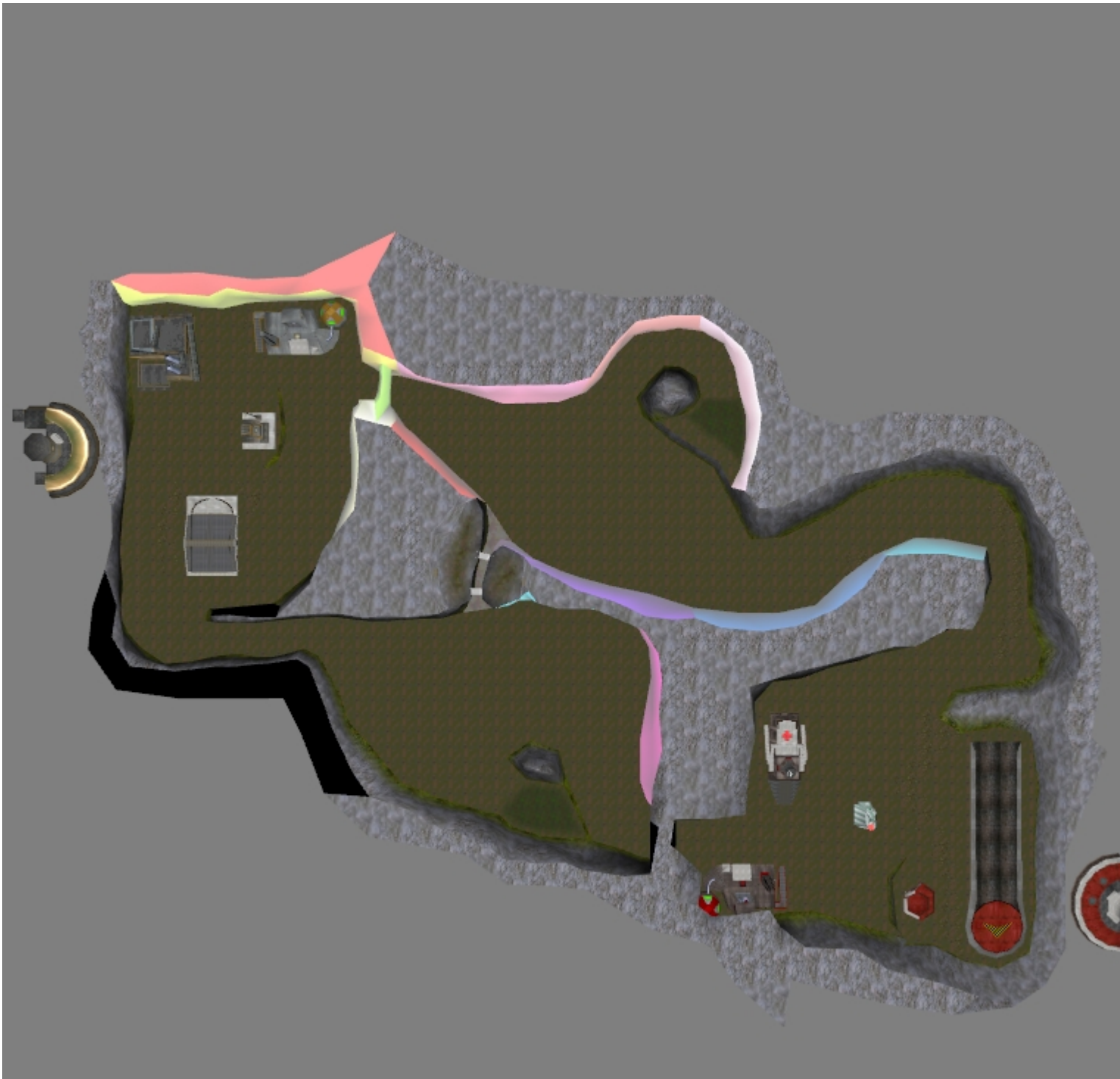

Subject: Re: Another WIP Map
Posted by [Dave Mason](#) on Tue, 14 Feb 2006 17:17:35 GMT
[View Forum Message](#) <> [Reply to Message](#)

Add some rocks and trees in, it's a very wide open space at the moment. Apart from that it looks like it will be a decent map to play.

Subject: Re: Another WIP Map
Posted by [DreamWraith](#) on Tue, 14 Feb 2006 20:01:48 GMT
[View Forum Message](#) <> [Reply to Message](#)

by the looks of it, nod's harvester is going to take about 133% of the time GDI's harvester is to complete a single run.

Subject: Re: Another WIP Map
Posted by [Renardin6](#) on Tue, 14 Feb 2006 20:52:08 GMT
[View Forum Message](#) <> [Reply to Message](#)

Add lightmaps. (yeah I want to see it everywhere.)

Subject: Re: Another WIP Map
Posted by [Dave Mason](#) on Tue, 14 Feb 2006 21:22:50 GMT
[View Forum Message](#) <> [Reply to Message](#)

DreamWraith wrote on Tue, 14 February 2006 20:01 by the looks of it, nod's harvester is going to take about 133% of the time GDI's harvester is to complete a single run.

The Nod refinery is alot closer to that tiberium than the GDI spot one. I think it will still take slightly longer though, 110% maybe.

Subject: Re: Another WIP Map
Posted by [JeepRubi](#) on Tue, 14 Feb 2006 22:35:58 GMT
[View Forum Message](#) <> [Reply to Message](#)

The initial path is longer for nod but the repeditive path is longer for gdi, most maps harvys dont go at the same time anyway.

Renardin6 wrote on Tue, 14 February 2006 14:52 Add lightmaps.

I would but im using gmax not 3ds max and i dont know how to use 3ds max anyway. When im done if someone would do it for me that would be great.

File Attachments

1) [harvy paths.jpg](#), downloaded 286 times

● Initial Path
● Repetitive Path



Subject: Re: Another WIP Map
Posted by [DreamWraith](#) on Wed, 15 Feb 2006 04:26:13 GMT
[View Forum Message](#) <> [Reply to Message](#)

Erm yes, my dyslexic self mixed up nod and GDI. I did mean GDI would take longer.

sure, some maps arent synchronized, but that is practically twice the distance now that you have lined it out. gdi will be at an economic disadvantage.

Subject: Re: Another WIP Map
Posted by [Aircraftkiller](#) on Wed, 15 Feb 2006 04:38:10 GMT
[View Forum Message](#) <> [Reply to Message](#)

Weld the buildings to the terrain, press S and turn on 3D snap. Shift and right click, set your snap settings to Grid and Vertex. Snap vertex points to the building edges, there's no reason for them to be sitting on the ground instead of being part of it.

Subject: Re: Another WIP Map
Posted by [Titan1x77](#) on Wed, 15 Feb 2006 04:38:12 GMT
[View Forum Message](#) <> [Reply to Message](#)

easy fix for the harvys.....play test the map and get the timing just right for both of them.

Some maps i have made the WF/AIR where in spots not ideal to get the harvy going at the same pace for both teams.

once you find the exact time for each team, Temp a new REF controller and change the load time for the team thats moving to fast...example would be GDI is quicker by 3 seconds...change unload time to 13 seconds for GDI's REF.

** make sure you delete the old REF controller, Save, and shut down LE....load it back up and THEN place the new REF controller.

If theres a large time gap....you then may consider re-arranging the base or Tiberium field setup.

From the looks of it....Nod might need an unload time of like 16-18 seconds.

Subject: Re: Another WIP Map
Posted by [DreamWraith](#) on Wed, 15 Feb 2006 04:38:20 GMT
[View Forum Message](#) <> [Reply to Message](#)

If it was just a small difference it would be one thing. But by the looks of it Nod would bring in money almost twice as often.

EDIT: maybe not quite twice as often, but for every dump gdi gets, nod would get about 1 2/3rds.

EDIT:

Also what you refer to as a one time disadvantage, would in fact be a recurring disadvantage every time the harvester was destroyed. say the harv gets destroyed 3 or four times, it starts to add up and GDI falls way behind.

Subject: Re: Another WIP Map
Posted by [Titan1x77](#) on Wed, 15 Feb 2006 04:43:30 GMT
[View Forum Message](#) <> [Reply to Message](#)

Aircraftkiller wrote on Tue, 14 February 2006 23:38: Weld the buildings to the terrain, press S and turn on 3D snap. Shift and right click, set your snap settings to Grid and Vertex. Snap vertex points to the building edges, there's no reason for them to be sitting on the ground instead of being part of it.

Shouldn't he just use vertex for the snap settings?

A grid point may be close to a vertex of the building and will leave a gap.

Once you do this you should save the cut out terrain around your buildings for easy building placement in the future....also use the flying buildings or else you'll have to do it again.

Subject: Re: Another WIP Map
Posted by [JeepRubi](#) on Wed, 15 Feb 2006 12:52:14 GMT
[View Forum Message](#) <> [Reply to Message](#)

I don't see the point unless the buildings go underground you shouldn't need it, or even want it because it just adds more polys to your map.

Subject: Re: Another WIP Map
Posted by [Spice](#) on Wed, 15 Feb 2006 16:12:07 GMT
[View Forum Message](#) <> [Reply to Message](#)

Wasted polygons at the expense of rendering the texture underneath the building. I'd choose wasted polygons, as you say. If seen renegade maps with 70,000 polygons run perfectly fine.

Maps look like literally shit when you don't do it anyways. In my opinion it looks like the mapper was being lazy.

Subject: Re: Another WIP Map
Posted by [Aircraftkiller](#) on Wed, 15 Feb 2006 18:51:41 GMT
[View Forum Message](#) <> [Reply to Message](#)

It adds a whole 400 polygons... Big fucking deal. It also allows you to create customized blending zones around buildings, like I have them set up in Glacier Flying, Glacier, and GlacierTS. In addition to that, it just looks better. It also prevents zbuffer arguing in the game where you didn't

place the building close enough to the terrain, which then makes the floor flicker from ground to floor over and over as your viewpoint changes.

There is absolutely no reason why you would not want to do this besides pure laziness.

Subject: Re: Another WIP Map
Posted by [PermaGrin](#) on Wed, 15 Feb 2006 19:02:01 GMT
[View Forum Message](#) <> [Reply to Message](#)

Jeep Rubi wrote on Wed, 15 February 2006 07:52I dont see the point unless the buildings go underground you shouldnt need it, or even want it because it just adds more polys to your map.

Zfighting is the reason you want to do this. As Ack stated, if you have two pieces of geometry laying too close to one another, the engine has a hard time determining which piece is actually on top. So what happens is one frame the game might think the concrete floor of you building is ontop (which it is) and the next frame the game may think the ground is above the floor (which it is not), which in turn cuase the goemetery to flicker between building floor and ground. One way to get around Zfighting besides cutting up the lower section and snapping the verts of the bottom verts of the building is to have the buildings floor far enough above the ground where the engine knows which is on top all the time, but this may result in a floating building. Best course of action is to take the time and cut up the surrounding area and delete the under lying mesh pieces and the border of the hole with the building.

Subject: Re: Another WIP Map
Posted by [DreamWraith](#) on Wed, 15 Feb 2006 20:28:59 GMT
[View Forum Message](#) <> [Reply to Message](#)

What about the harvester situation? Are you going to address it?

Subject: Re: Another WIP Map
Posted by [JeepRubi](#) on Wed, 15 Feb 2006 20:40:17 GMT
[View Forum Message](#) <> [Reply to Message](#)

I will adress the hary situation when i have a playable version using Titan's tequinqe.

As for the building welding, ill give it a try. Atm i have a lot of big assignments due at school so i wont have much time to work on it.
